

1. ASCENDO WINDBREAK INSTALLATION

The Ascendo windshield will be ready for you to install simply by anchoring it to the ground or positioning it in the area of your choice if you have the wheeled base option.

It is recommended to fix the windbreaks to the floor with screws of diameter between 8 and 10 mm, and a minimum length of 90 mm.

• Leveling

The system can be functional even if it is installed on a sloping surface, but it is important that they must have the same slope in an installation with several aligned windbreaks. Ideally, windbreaks with bases that are anchored to the ground should be level with respect to the ground.

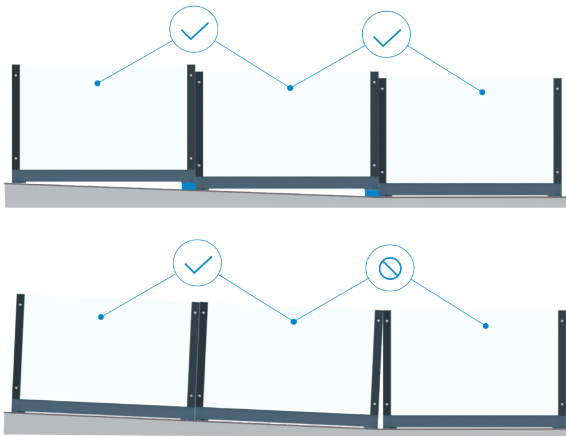

2. VERIFICATIONS AFTER INSTALLATION

Once you have received the windbreak and it has been installed in the desired area, **you must check the function of the movable glass.**

Normally, it should arrive fully functional and not have to perform any operation on it, **but if it is detected that the glass remains elevated or rises on its own or, on the other hand, when lifted, it lowers on its own or does not reach the end of its travel**, it means that the transmission system has drive system not adequately loaded as it should be.

In any of these cases, the transmission system must be adjusted. To do so, you steps described in the **'REGULATION'** section on the next page

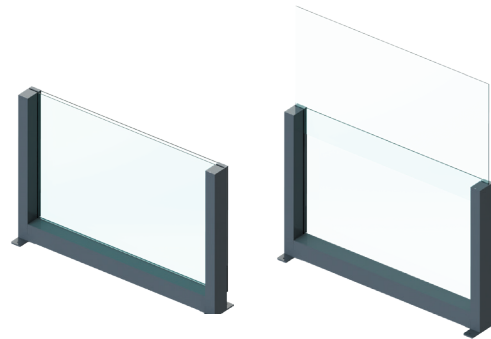

3. 90° CORNER INSTALLATION

To install two windbreaks that form a 90° corner, it will be necessary to fasten them together for safety reasons. To do this, you must follow the steps described below:

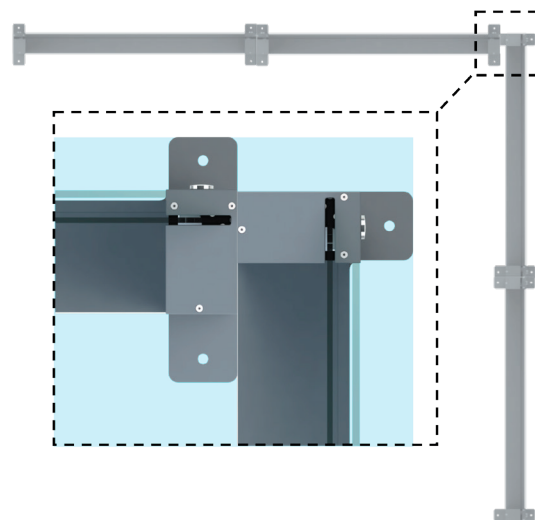

3.1. ACCESS TO INTERIOR

Raise the sliding glass panel and remove the side caps* from the posts that are overlapping. *** To avoid scratching the cassette cover, it is advisable to place a sheet of paper over it before removing the side caps.**

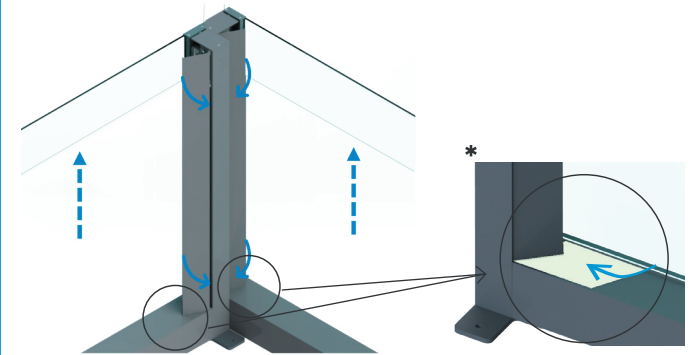

3.2. FIXING THE FIXED PROFILES

Fix both posts with M6 bolts and nuts, using the holes drilled in both profiles.

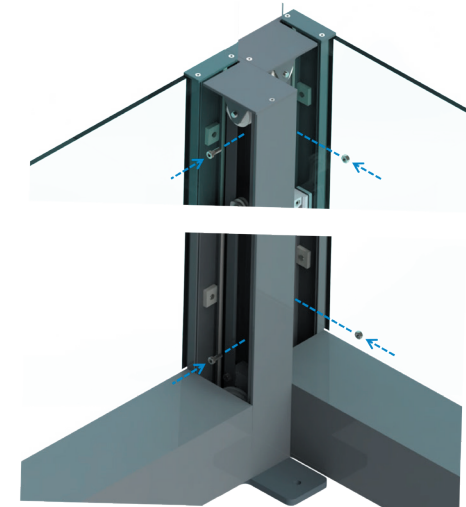

REGULATION

STEP 1. ACCESS TO THE INSIDE

Lift up the movable glass and remove the side covers* and drawer cover to be able to adjust the windbrake. It is important that this is done in the order shown (1.1, 1.2). ***To avoid scratching the drawer cover, it is advisable to place a sheet of paper on the drawer before removing the side covers.**

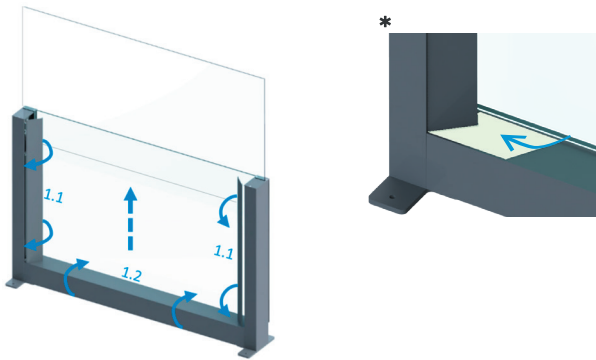

STEP 2. RELEASE TRANSMISSION SPRING

Lower the glass back down to its lower stop. With the help of a metal rod or shaft with a diameter of up to 12 mm, it should be inserted in one of the holes of the rotating terminal to support the force stored in the spring. Then unscrew the two screws securing the spring to the drive shaft to release it. **At this point it is very important that the rotating end of the spring is secured to the drive shaft. as a recommendation, it can be kept locked in place by letting the metal shaft rest on the floor.**

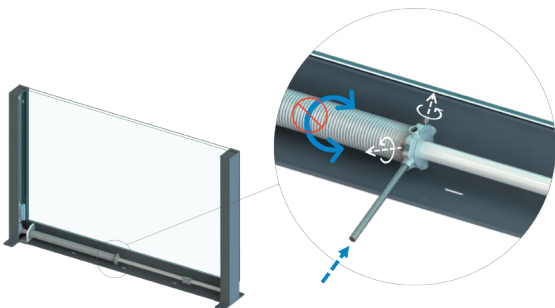

STEP 3. INCREASING OR DECREASING SPRING FORCE

3.1. Increase spring force

If you notice that you have to use too much power to lift the glass or that the glass does not rise to the upper end of the stroke, the spring must be further loaded by turning it upwards with the help of the bar mentioned above. Usually a quarter or half turn will be enough.

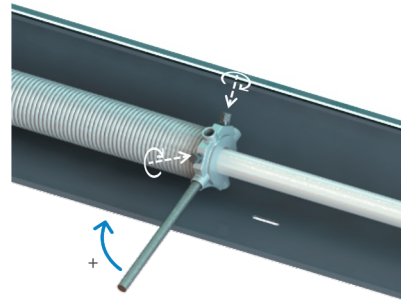

3.2. Reduce spring force

If you notice that the glass in its lowest position rises on its own or that in the middle of its travel it lifts by itself without applying any force you must unload the spring by turning it downwards with the help of the bar mentioned above. Typically a quarter or half turn will be enough.

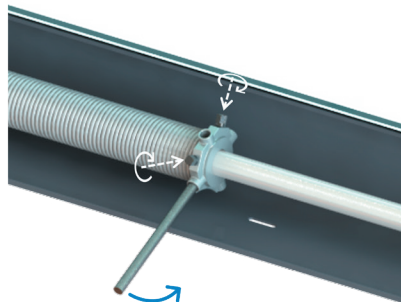

Once any of the above steps have been carried out, without releasing the spring tensioning rod, you must screw the two screws that hold the spring to the shaft. It is recommended to place one of the two screws in the groove of the shaft.

From this point on, you will be able to check the correct functioning of the windbreak.

STEP 4. COMPLETE INSTALLATION

Once it has been checked for proper operation, reassemble the drawer cover and then the side covers*. It is important to follow the order indicated (1.1, 1.2).

*** To avoid scratching the drawer cover, it is advisable to place a sheet of paper on the drawer before closing it.**

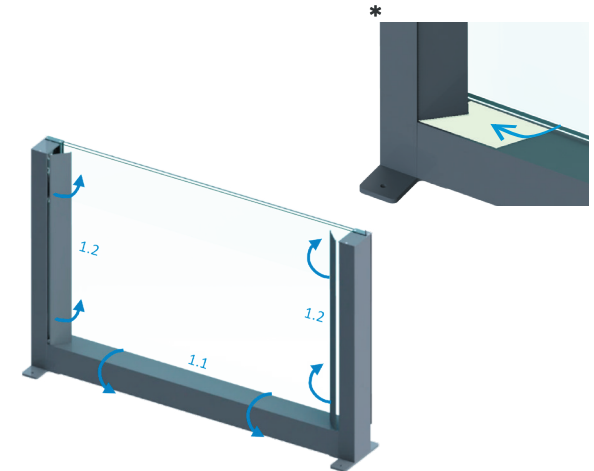

If you have any questions, please do not hesitate to contact our Technical Department on 00 34 952 198 752.