



INSTALLATION INSTRUCTIONS

**FRAMELESS SLIDE AND TURN SYSTEM
STAR SERIES**

acristalia

1 BEARING ARRANGEMENT ACCORDING TO PANEL TYPE

In installations without intermediate opening, the bearings and pivot bearings are mounted as standard in the upper panel plinth.

In installations with intermediate opening, the upper bearings and pivot bearings are mounted in the spacer profile to provide the pivoting and swing functions.

In these instructions, the mounting is illustrated on the spacer profile.

The mounting on the top door panel plinth is the same.

Installation in the top door panel plinth

Pivot/end leaf, sliding panel, fixed part

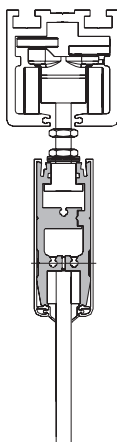

Installation in the spacer profile

Pivoting sliding door panel, swing-out sliding door panel

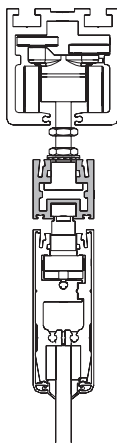

2 SYSTEM INSTALLATION

2.1. Installing the substructure and top guide

If it is not possible to anchor directly to the floor surface, a horizontally aligned (lengthwise and crosswise) and load-bearing substructure is required. When determining this substructure, take into account the attachment of the top guide and the total weight of all leaves in the parking area.

Screw the upper guide along its entire length (also in the stacking area) to the substructure. The fixing points of the top guide on the substructure are approx. every 300 mm in the straight sections and approx. every 100 mm in the stacking area.

Caution!

Fit the profile connections (except for the inspection part, see section 2.5 "Assembly and disassembly of the inspection part") with the fastening parts (a) including the pins in such a way that a good linear travel is ensured.

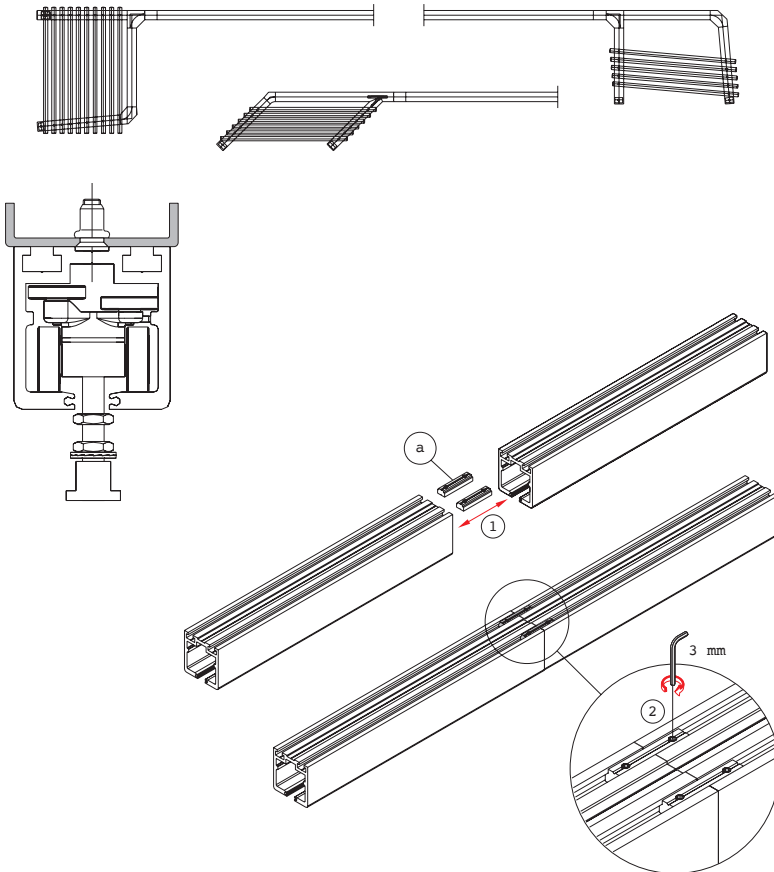

2.2. Floor door closer and floor bearing

Floor door closer (BTS)

If the frameless slide and turn system's door is fitted with a recessed bottom door closer, a recess must be made in the floor for this door closer, which must be covered with a stainless steel cover plate.

The shaft of the door closer must be flush with the upper bearing. The dimensions of the cut-out can be seen in the following image.

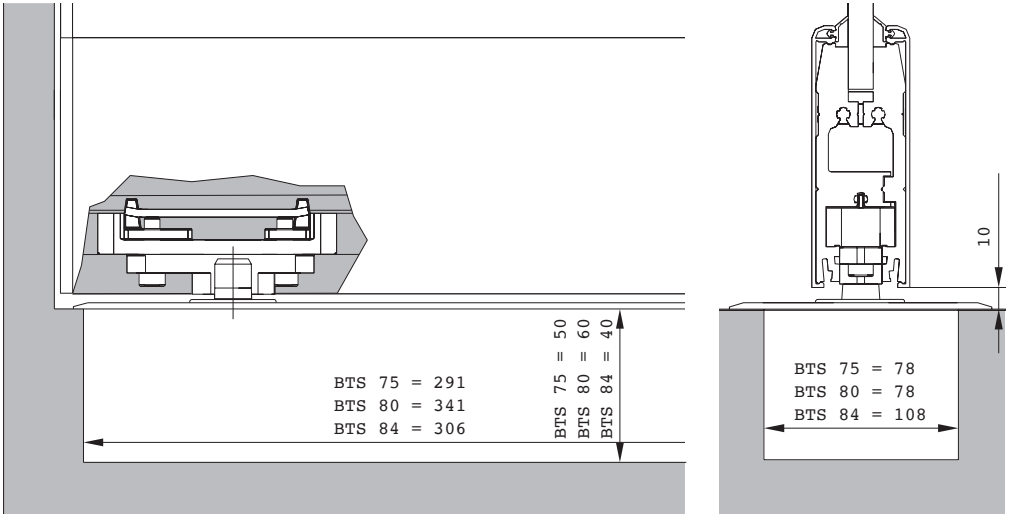

Floor bearing

To adjust the floor bearing (a), loosen the fixing screws (b), move the floor bearing and retighten the screws. To adjust the height, use the included washers (c), (3 pieces, each 1 mm thick). The axis of the floor bearing must be plumb to the axis of the upper bearing.

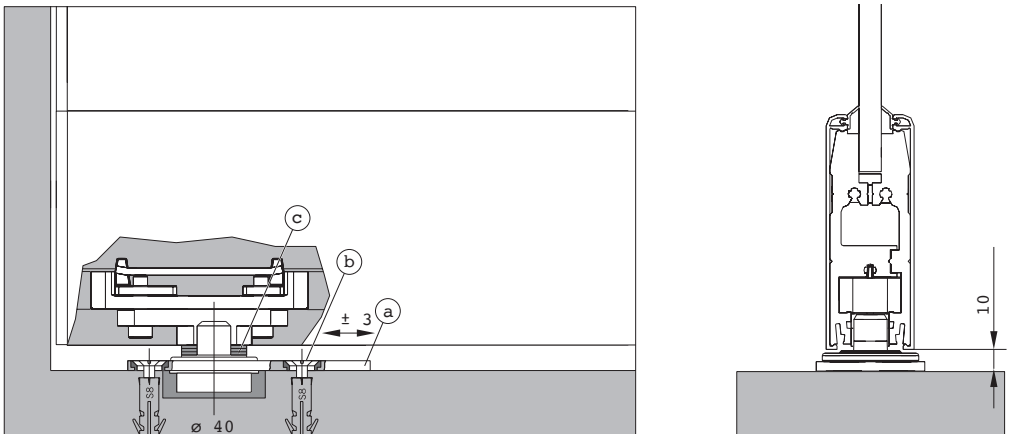

2.3. Fitting the pivoting door panel

Attention!

If the frameless slide and turn system is equipped with a fixed curtain panel, this must be mounted first (see page 16 for installation).

Mount the panel ① by inserting the pivot in the upper bearing ② and then inserting it into the floor bearing ③.

③.

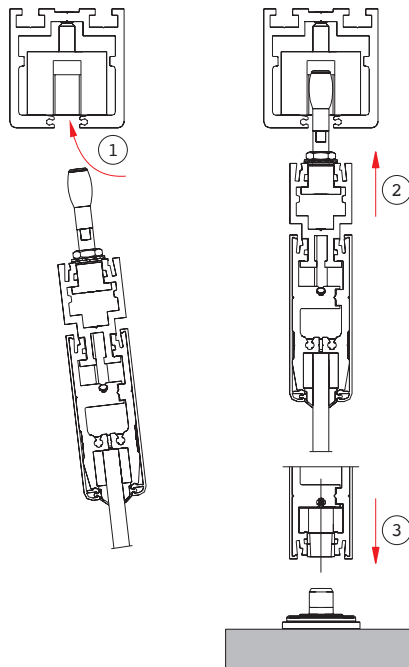
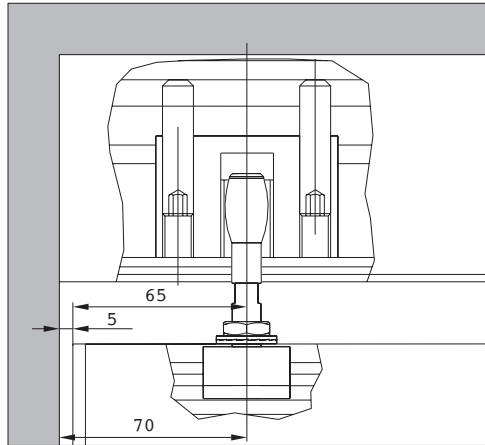

Turn the bolt in the upper bearing (8 mm open-end spanner) until the surface of the key is flush with the lower edge of the upper guide (4). Then insert the locking plate into the guide channels using pliers and slide it firmly onto the pivot (5).

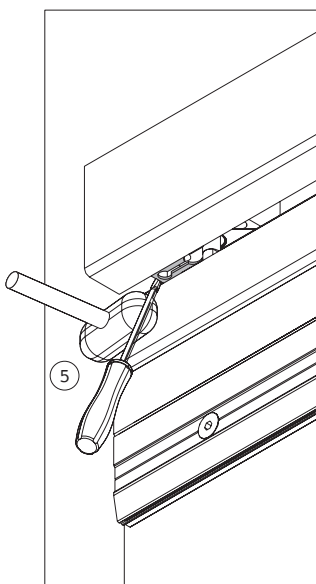
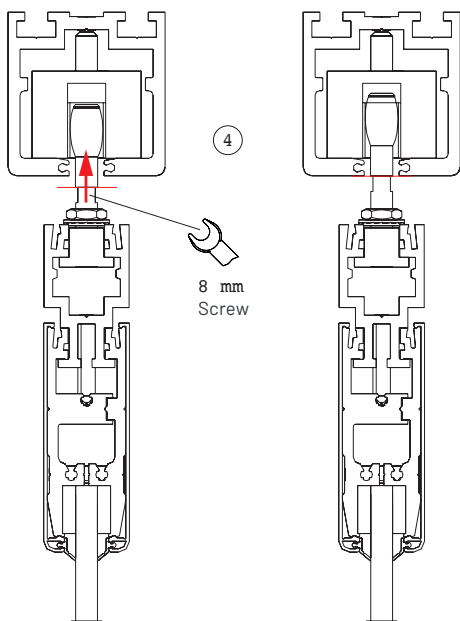

2.4. Bearing arrangements

Bearing deflection in the parking area::

The bearing arrangement is decisive for the correct guidance in the stacking area.

On each panel, one high bearing should be mounted on the right and one on the left.

Standard stacking area 1

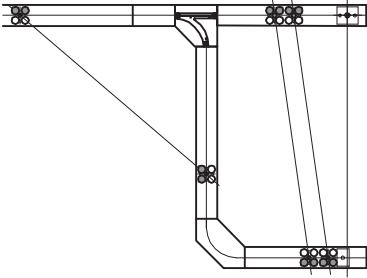

Stacking position perpendicular to the direction of travel (90°).

Standard stacking area 2

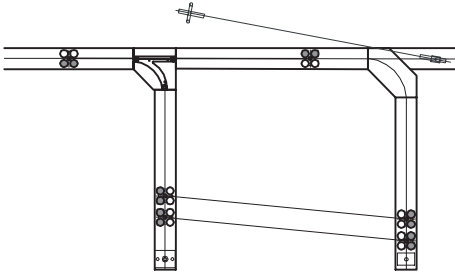

Stacking position parallel to the direction of travel (90°).

Standard stacking area 3

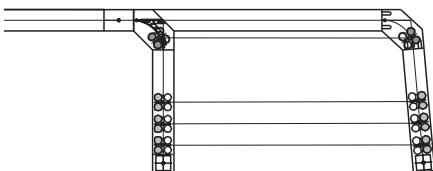

Stacking position parallel to the direction of travel (95°).

Bearing in straight section

=

high left-hand bearings (a)

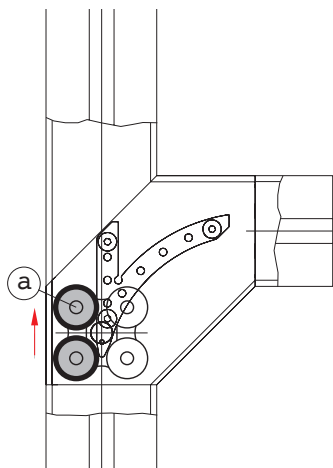

Bearing in angled section

=

high right-hand bearings (a)

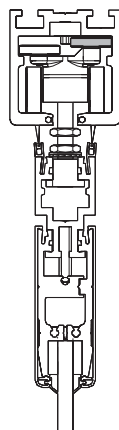
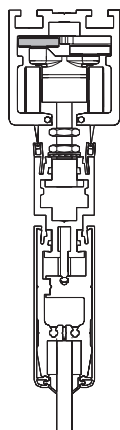
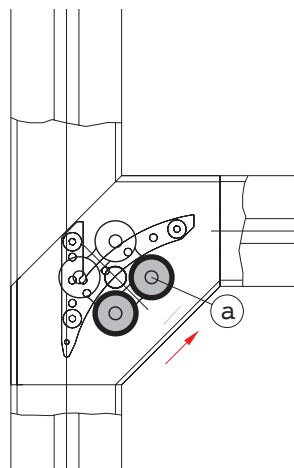

2.5. Mounting and dismantling the overhaul part

The overhaul part can be removed to replace defective bearings.

To do this, remove the knurled pins with cylindrical pin from the revision part ① and remove screw ②.

The revision part must be screwed in continuously.

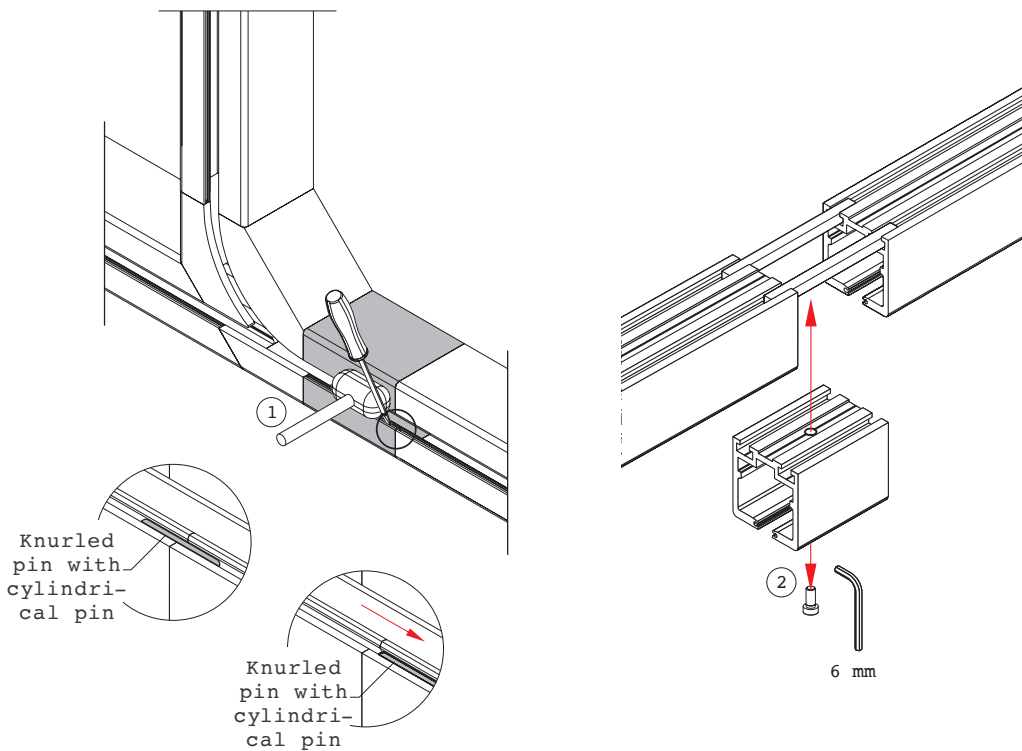

2.6. Hanging the sliding panels

- Slide the bearings (a) with the suspension blocks (e) of all panels into the upper guide.
- **Observe the arrangement of the bearings (high and low, see section 2.4).**
- Remove the covers of the upper plinth and then insert the suspension blocks.
- Place the panel on 12 mm shims on the floor and insert the suspension blocks on the right and left into the upper plinth (d).

Aligning the height of the panel:

- Align the panel in height so that at the bottom there is a 10 mm gap between the floor and the lower plinth. To adjust the height, loosen the nut (c). Adjust the height using the nut (b) (17 mm open-end spanner).

Left turn = greater distance to the ground
Right turn = shorter distance to the ground

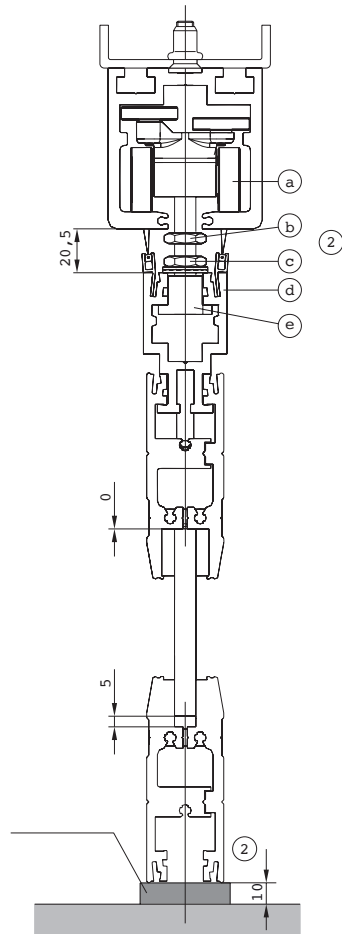
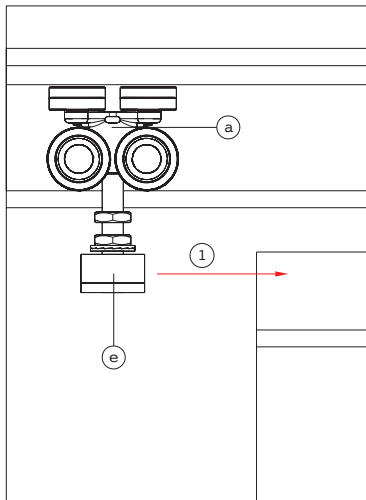

2.7. Aligning the panel in the parking area

Move the hung panel into the parking area and align it laterally with the first panel. The panels must be moved carefully. The bearings must not be fixed in this part, in order to adapt the correct distance in the stacking area. If necessary, loosen the nut (C). Align the panel in the station area. Retighten the nut (C) after alignment.

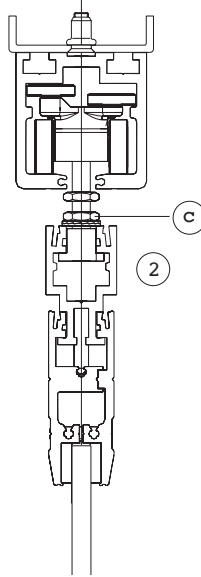

Lateral alignment in the stacking area

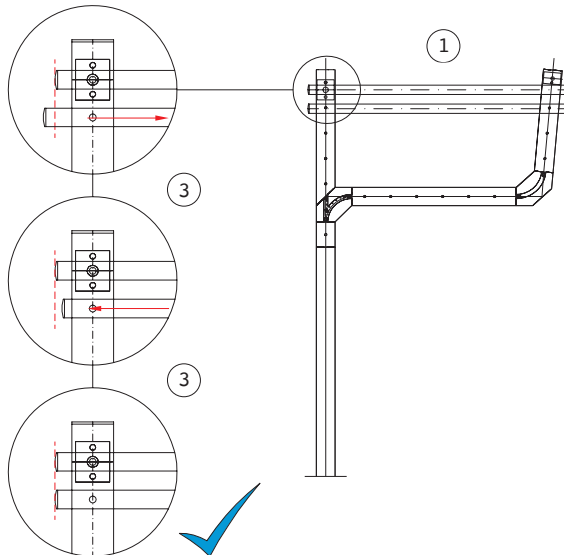

2.8. Aligning the panel in the front area

Aligning the panels:

Align the pivoting panel H1 (allow 12 mm play in relation to the wall if it has a Z-Seal, or 5 mm if it does not have one). Close all the panels (bringing them towards the front). Then align the other panels (H2-H4) according to the already aligned pivot panel (H1), leaving 5 mm of play respectively.

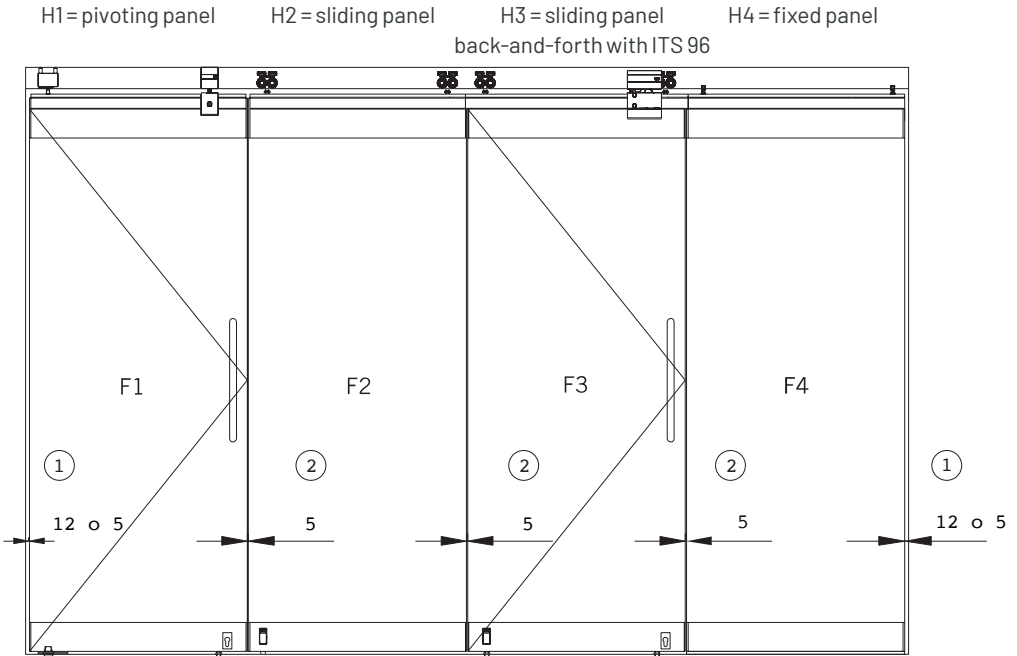

2.9. Preparation on the ground

As standard, eccentric bushes are used for locking.

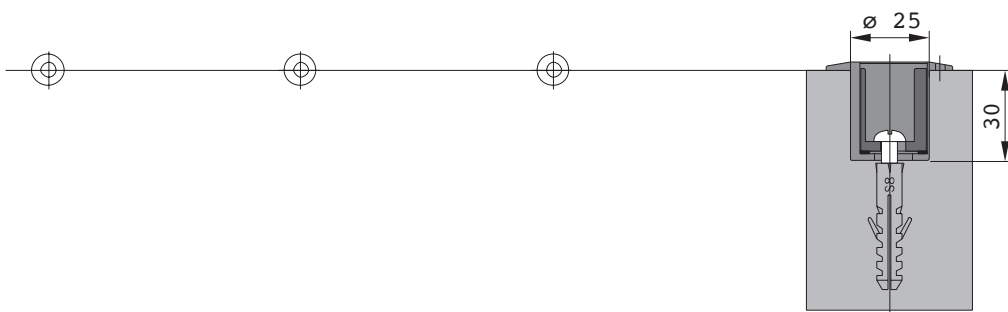

Bore 25 mm diameter and 30 mm depth for the eccentric sleeve and additionally 8 mm diameter for dowels. Align the eccentric sleeves(double eccentric) and fix it with the screw in the centre.

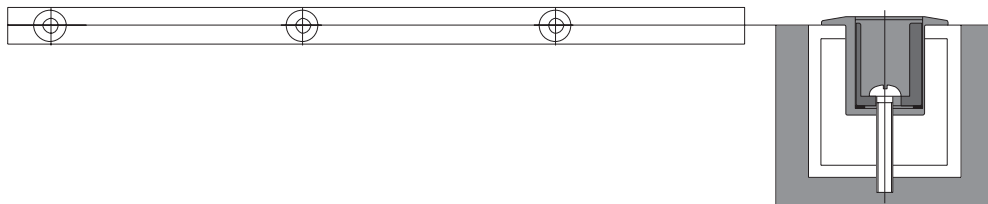

Insert the eccentric sleeve into the through tube.

2.10. Bore for the eccentric sleeve

Adjustable eccentric sleeves are used as standard version with plastic inner sleeve.

Drill the 8 mm hole for the dowel and, in addition, the centred hole for the eccentric sleeve of 25 mm diameter, 30 mm deep and at a distance of 65 mm to the outer edge of the panel.

Excentric sleeve

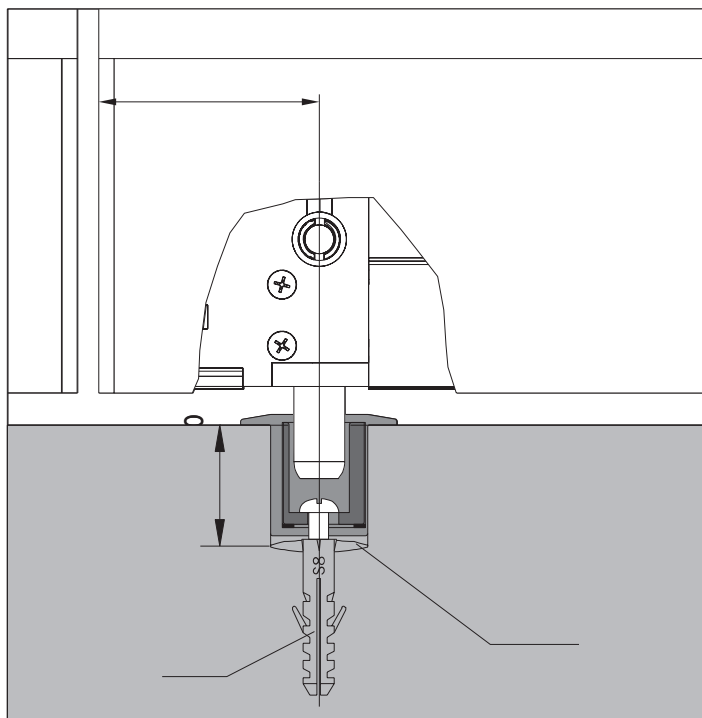

$\pm 2,5$

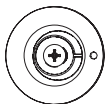

3 FIXED PANEL INSTALLATION (OPTIONAL)

3.1. Montar el perfil

Only if the system is equipped with a fixed panel, mount the profile on the floor. To do this, align the profile according to the installation instructions. Mark the drill holes and drill the holes. Fix the profile to the floor with screws and dowels..

Attention!

The fastening material must be suitable for the construction material.

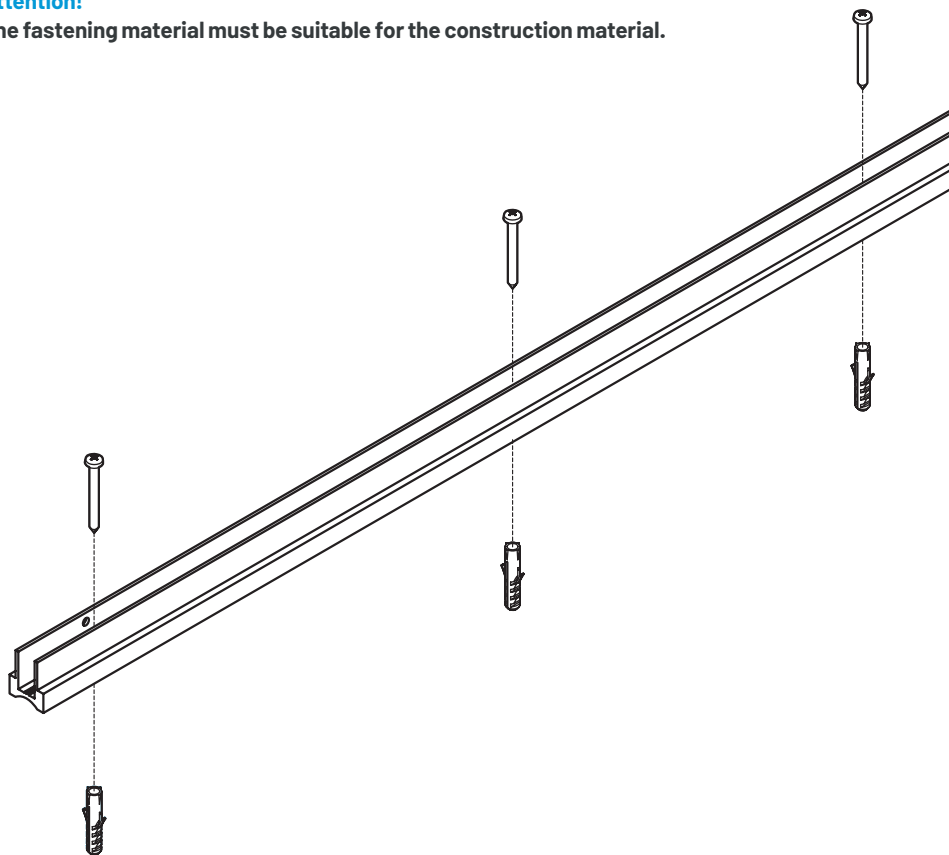

3.2. Mounting the fixed blade

The fixed panel has fixed panel supports instead of bearings.

- Turn the head of the fixed blade 90° ①, so that the fixed blade can be inserted into the upper guide.

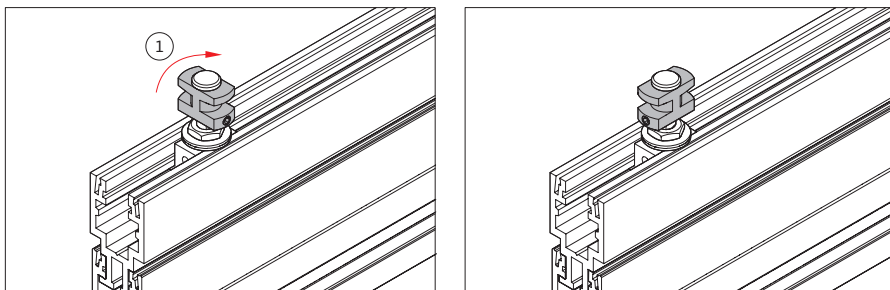

- Insert the fixed panel supports from above into the upper guide ②.

- Place the panel on the floor bearing ③.

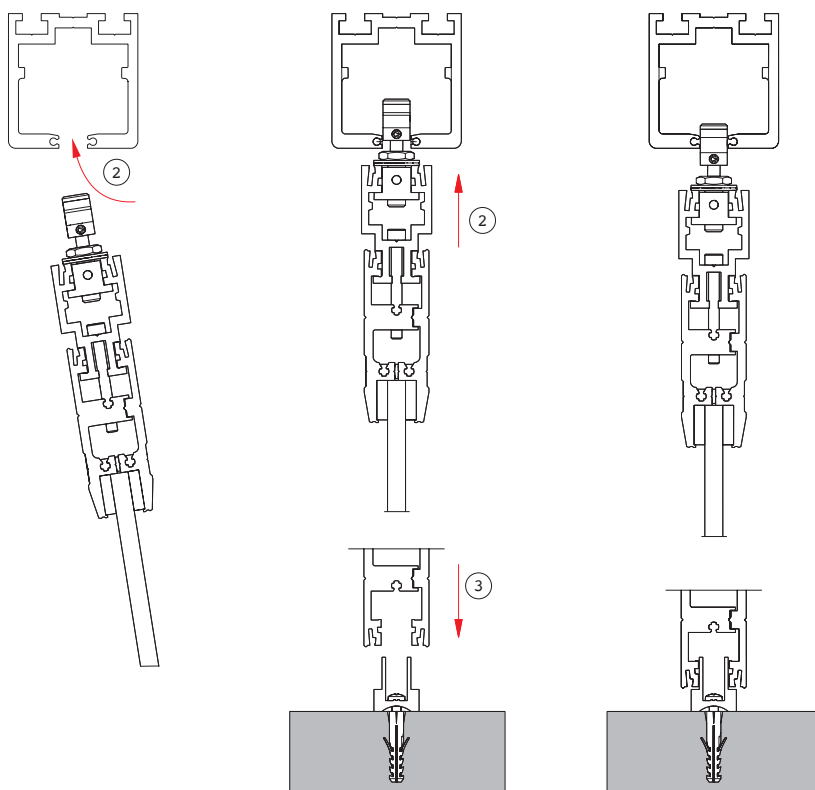

Remove the nut from the fixed panel support ①. Turn the bolts up or down as far as necessary so that the fixed panel holder is securely attached to the upper guide ②. Turn the fixed panel head 90° so that the fixed panel holder engages in the upper guide ③. Secure the position of the fixed panel support with the threaded pins ④. Secure the lifting of the panel with the nuts ⑤. Screw the fixed panel with the profile to the floor ⑥.

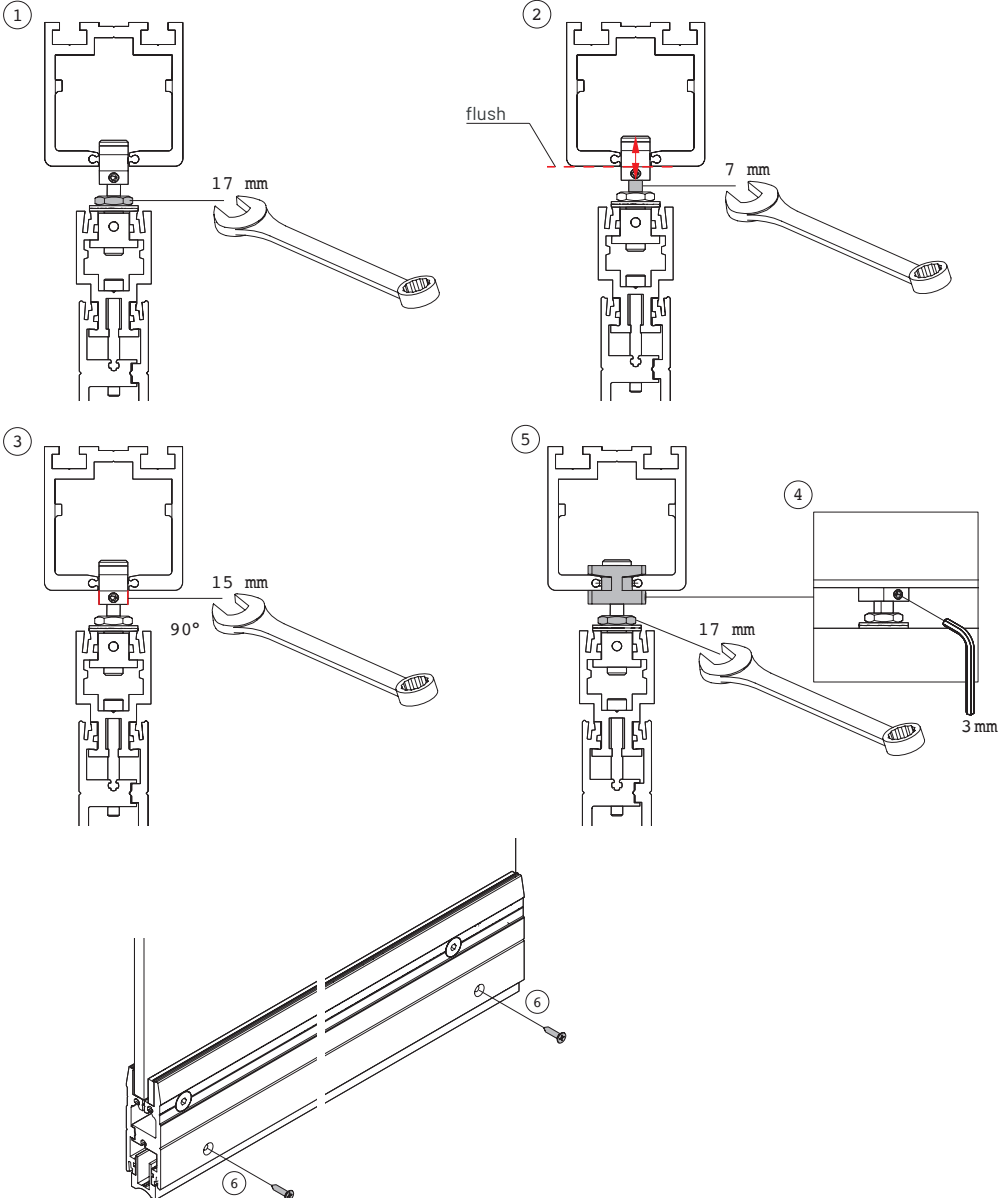

4 CARDAN LATCH MOUNTING (OPTIONAL)

① Position, fix and secure the panels with wedges.

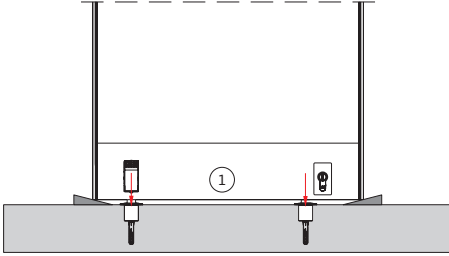

② Screw in lightly.

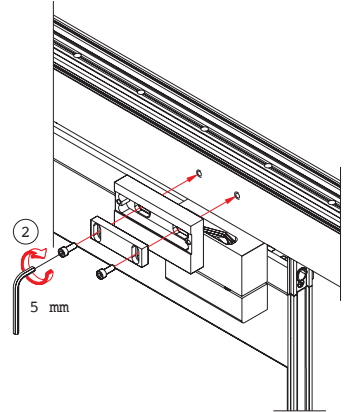

③ Turn sickle upwards.

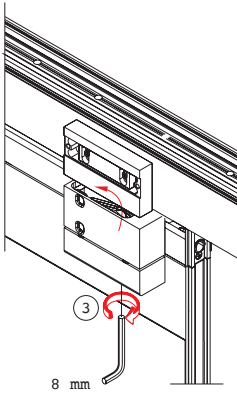

④ Check adjustment.

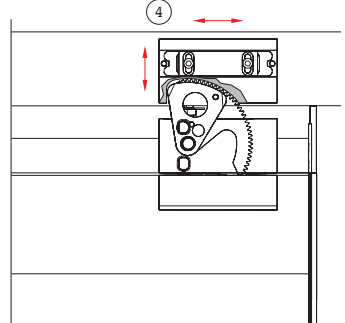

⑤ Tighten.

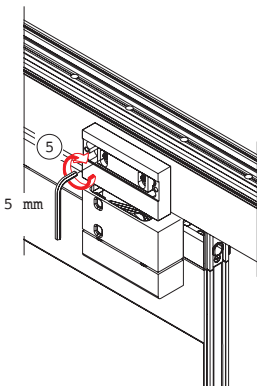

⑥ Put the lid on.

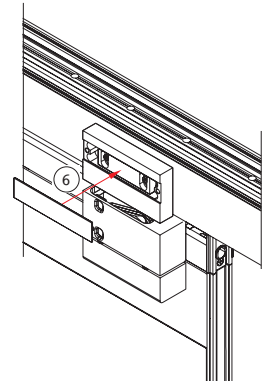

5 INSTALLATION OF A DOOR CLOSER TS 92/93 (OPTIONAL)

If a door closer is planned for a pivoted door panel, the upper plinth is prepared for this.

Mount the spacer plate on the door guide rail or on the support profile ①.

Make sure that the elongated holes are located in the upper area of the spacer plate ②.

Drill the upper guide rail according to the given drilling pattern (2x M5) ③.

The drilling template of the door closer cannot be used for this assembly.

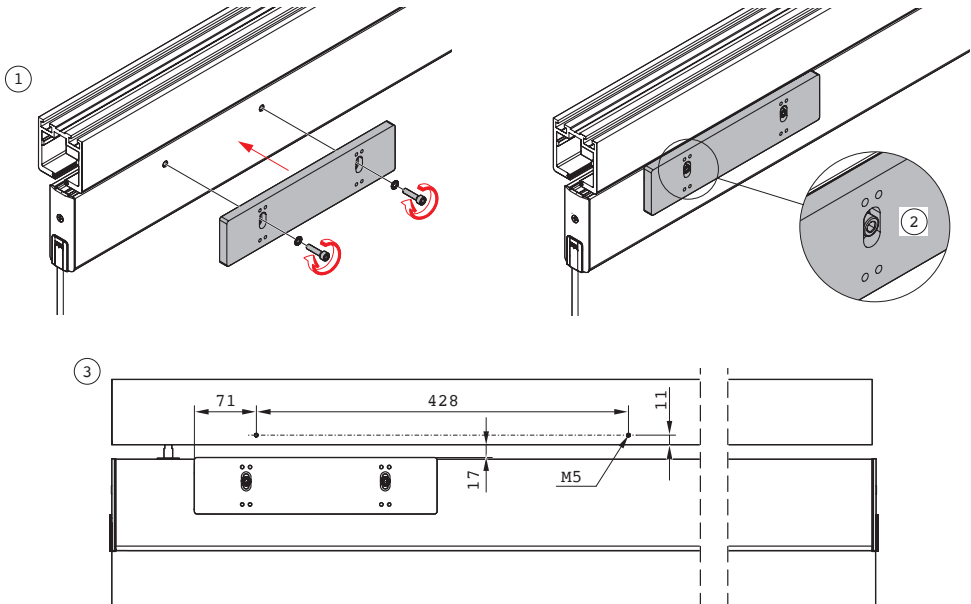

Position the mounting plate of the door closer in the middle of the already mounted spacer plate.

Fit the runner rails flush with the top guide from below.

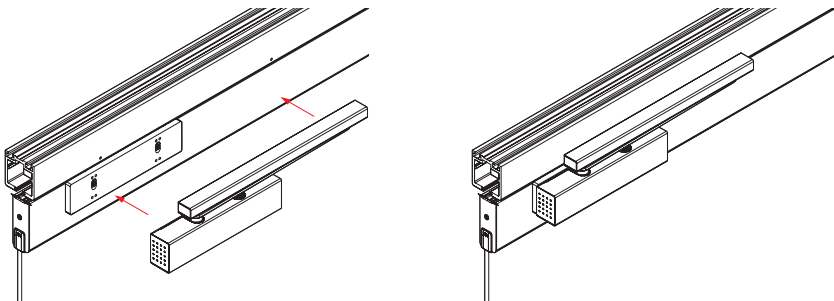

6 SETTING THE ZERO POSITION ON DOOR CLOSER ITS 96 (OPTIONAL)

Open the pivoted/swinging sliding panel. Loosen the screw on the clamping piece (3 mm Allen key). The ITS 96 can now be adjusted ± 2 mm to the zero position. To do this, press the ITS in the direction of the side of travel and then tighten the screw again.

