

FIXED WINDBREAKER FIXENDO SERIES

Acristalia, SL - B92813096

c/ Santa Laura, n° 9 - 29651
Mijas Costa - Málaga (España)

Customer Service: 952 198 752
info@acristalia.com | acristalia.com

REQUEST FOR QUOTATION ORDER CONFIRMATION

QUOTATION NUMBER: _____ DATE: _____

REF.: _____

Company: _____

VAT number: _____ Ordered by: _____

Email: _____

Tel.: _____ Fax: _____

MOUNTING SKETCH (plan view)

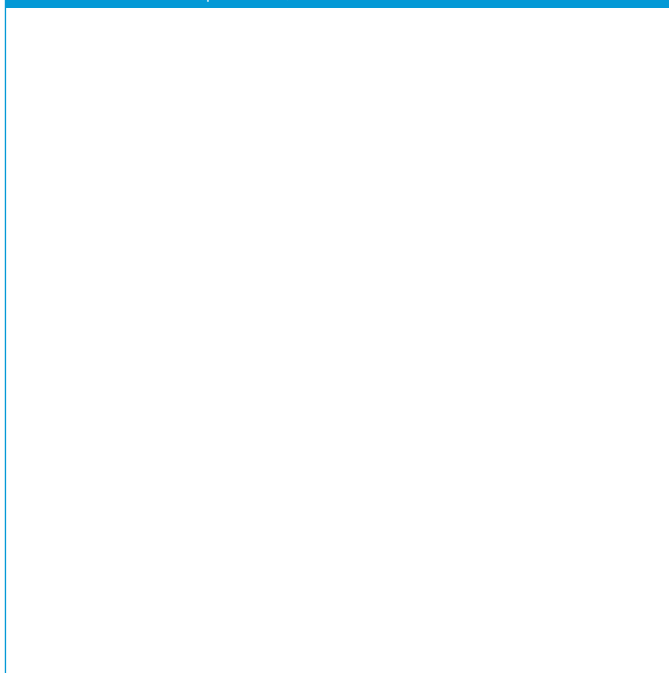

DIMENSIONS

Height*: _____ mm
(Maximum height 1900 mm).

Width: _____ mm Amount: _____ uds.
(Width up to 2000 mm).

GLASS OPTIONS

- Flat glass Templated 8 mm (windbreaker mode)
 Templated-laminated 5+5 (railing mode)



- Arched glass semi-circular Templated 8 mm (windbreaker mode)
 Templated-laminated 5+5 (railing mode)

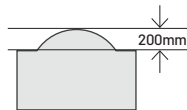





**(In this case, the total height indicated in the DIMENSIONS section includes the 200 mm of the arch, ALWAYS without exceeding 1900 mm).*

ALUMINIUM FINISHES

- Matt white (RAL 9003M)
 RAL _____
 Anodised _____
 Wooden imitation _____ Others _____

OPTIONS/SETTINGS

- Fixed to the ground (DEFAULT) 
- Wheels  Planter  Planter and wheels 

CUSTOMISED DIGITAL PRINTING

YES NO

In order to be able to execute the production, you will have to send us a file for printing. Always in CMYK colours, preferably in vectors, or jpg image with a minimum resolution of 300 dpi, at the actual size you require.

The design submitted must fit the printable area, keeping non-printing margins of 80mm on each side.

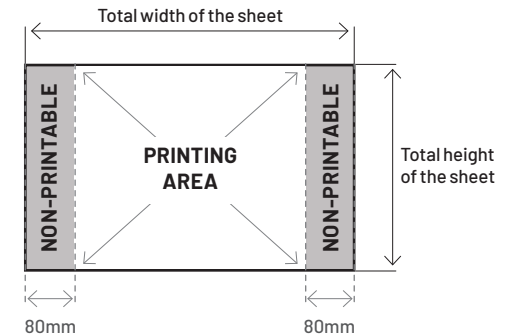

COMMENTS:

By signing this document confirming the order, the document will be considered a purchasing commitment for all purposes. However, Acristalia will not begin to manufacture the product until it receives this document fully filled out together with the signed and stamped quotation, and the proof of payment for order confirmation, according to the agreed payment conditions.

ACRISTALIA S.L. will deliver the product in accordance with the features, measurements and design as specified in this document.

Acristalia will not assume responsibilities for any mistakes or omissions while filling it out. For further information on legal aspects, see the back of this sheet or visit our website at acristalia.com

I have read and accept the general conditions of sale on the following page.

SIGNATURE AND STAMP (required)

DATE: _____

ACRISTALIA GUARANTEE

ACRISTALIA PRODUCTS

The products manufactured by ACRISTALIA S.L.* are **guaranteed for 5 years from the reception of the product**. This guarantee covers possible manufacturing defects or faults in the materials used for the same:

- **Guarantee on glass** in accordance to the tolerances included in the standards UNE-EN 12150-1:2016 + A1:2020, UNE-EN 14449:2006, UNE-EN 1279:2019.
- **Guarantee on aluminium materials** with dimensional tolerances according to UNE-EN 755-9:2016, mechanical characteristics according to UN-EN 755-2:2016, chemical properties according to UNE-EN 573-3:2020, technical inspection and supply conditions according to UNE-EN 15088:2006.
- **Guarantee against deformation of the aluminium**, due to the lack or insufficient tempering of the profiles.
- **Guarantee on finishes, coating and anodising** following the guidelines of the European quality mark Qualicoat, Qualanod, Qualideco, approved by the Ministry of Development for powder surface treatments.

In the following cases, the product shall be governed by Law 23/2003, of July 10, on Guarantees in the Sale of Consumer Goods, and shall be covered by a 2-year warranty:

- **Discoloration or deterioration of the glass seals**, where applicable.
- **Pleated system components.**
- **Any product or component not manufactured by Acristalia.**

***5-year Acristalia warranty.** Acristalia is the direct manufacturer, with no intermediaries, of the following products: Standard Series and Basic Pro Series (Frameless Slide & Fold Glass Curtain System); Tandem Series (Frameless Sliding Glass Door System); Sliding Series, Minimalist Series and Panoramic Series (Sliding Glass Roof Systems); Railing Series (Glass Railing System); La Pér-gola de Acristalia (Bioclimatic Pergola System); Ascendo Series retractable (Retractable Windbreak System); Fixendo Series (Fixed Windbreak System); and Brisa Series (Panoramic Vertical Sliding System).

ACRISTALIA SOLUTIONS

ACRISTALIA S.L. shall be liable for any incident involving parts or defects imputable to the manufacture. **The following are not covered by the guarantee:**

- **Damage or deterioration of any part or component** caused by improper installation, misuse of the product or incorrect maintenance of the same.
- Damages caused by **building movements, natural catastrophes, or indirect damages** caused by other external elements not related to ACRISTALIA products (awnings, antennas, roofs, installations in general).
- **Glass shattering.**
- **Acts of vandalism** causing damage to the product.
- **Scratches or marks on the glass or aluminium** not communicated by fax or e-mail to ACRISTALIA S.L. within a maximum period of 48 hours following the reception of the goods.
- Deformations of the aluminium produced by the **displacement or movements of the structure of the building.**
- **The result of the colours printed in the vitrified digital printing process.** The colours in the file are approximate orientation colours, as there are multiple factors that influence this appearance: resolution and type of screen, brightness calibration, contrast and light colour temperature... Acristalia is not responsible for any colour changes resulting from this circumstance, as it will be guided by the CMYK percentages of the files received.

GENERAL TERMS AND CONDITIONS OF SALE

GENERAL TERMS

1. Since this is a totally personalised product in terms of size, shape and finish, **NO RETURNS OR CANCELLATIONS ARE ALLOWED.**
2. Although Acristalia products are accepted by most homeowners' associations, if this is not the case, **ACRISTALIA S.L. is not involved in any litigation between the purchaser or owner of the property and the homeowners' association or any other party involved.**
3. **In the event that Carriage Paid To delivery has been agreed, the product will only be delivered to the company that requested it and at its address at street level.** If delivery of the product is not possible for reasons attributable to the ordering company at its home address, the ordering company shall be responsible for all additional costs, such as transport, delivery or any other cause.
4. ACRISTALIA S.L. is a wholesale company that only supplies its products to professional installers, therefore **ACRISTALIA S.L., will only be responsible for the correct manufacture of the products supplied, never for possible flaws or errors in their measurement, request or handling, as well as for problems caused by incorrect installation.** Acristalia will manufacture the products requested by the professional, regardless of the location, use or weather conditions to which the installation will be exposed. Acristalia is therefore exempt from any liability in this regard.
5. ACRISTALIA S.L. will repair or replace the components or products with manufacturing defects, **without being responsible at any time for the work or costs involved in the reinstallation of these products**, as these are part of the guarantee that the installer will provide to its customers

IMPORTANT

This contract is signed in Fuengirola (Malaga), and the customer states expressly that he/she abides to the courts and tribunals of this city in case of resolution of any controversy that may arise between the parties in relation to the interpretation or application of this contract, expressly renouncing to any other jurisdiction that may be applicable to him/her.

DATA PROTECTION

The data of the customers are included in a file owned by ACRISTALIA, S.L. for the execution of the present contract and the correct management of the commercial relationship. To exercise your rights of access, rectification, opposition, deletion, limitation of processing and portability, you may contact us by writing to the address given in this document.

USO Y MANTENIMIENTO

You can find the Use and Maintenance Manuals for the different series on the Acristalia website acristalia.com. We recommend downloading, explaining and delivering the document in physical format to the end customer for the correct and long-lasting operation of the enclosure.

Signature and stamp
(Mandatory)

